



AAS 
AUGSBURG AIR SERVICE



Over 40 Years of Experience



**Sales and Maintenance
Of Business Aircraft**

About us



SERVICE CENTER FOR
BEECHCRAFT & HAWKER
★★★ CESSNA ★★★

 **EMBRAER**
Executive Jets

AUTHORIZED SERVICE CENTER



nextant aerospace
SERVICE CENTER



Service Center for various brands



- **Over 40 years of experience**
- **Approx. 80 employees**
- **3 service hangars (total: 7.500 qm²)**

- **Allround service for international clients**
- **24 hours per day – 365 days per year**

- **1972 Foundation of the Wolfgang Denzel GmbH**
- **1985 Take-Over by Hans Schneider. The company is renamed to Beechcraft Vertrieb und Service (= Beechcraft Sales and Service) GmbH according to its authorization as service center. 60 employees**
- **2004 Merger of the two repair stations Augsburg and Baden-Airport in one huge maintenance facility with a new, extensive hangar at Augsburg Airport**
- **2005 Expansion: Addition of main hangar 1, approx. 80 employees**
- **2014 Atlas Air Service AG acquires Beechcraft Vertrieb & Service and renames it later to Augsburg Air Service GmbH**

The company is an independant subsidiary (under the leadership of managing director Florian Kohlmann)

Certifications



CAMO+ Organisation

DE.CAMO.0002

EASA Part 145

Maintenance Facility
DE 145.066

FAA Repair Station

BB6Y0720

Location: Augsburg – Germany (EDMA)



Advantages:

- in the heart of Europe
- 30 minutes to Munich (by car)
- no airport slots
- low fees
- airport of entry
international arrival with customs

Service Hangars



Hangar 1 – Turboprops & Jets

Service Hangars



Hangar 2 – Piston aircraft

Service Hangars



Hangar 3 – extra space for several purposes



Ground Run Box

- 1. MRO:**
Maintenance, repairs + modifications
- 2. Avionics & Instruments:**
Installation, operational tests + upgrades
- 3. Interior:** Refurbishment & deep cleaning
- 4. Paint Shop:** Complete / partial, also polishing / sealing
- 5. Spare Parts Sales:**
Beechcraft, Cessna, Embraer, Hawker & other brands
- 6. Aircraft Sales:** Pistons, Turboprops & Jets

- **CAMO (Continuous Airworthiness Management Organisation)**
- **Professional documentation due EASA/FAA policies**
- **Airworthiness review**
- **Pre-Purchase inspections**
- **AOG-Service (Stand-by)**
- **Major Repairs + Modifications**
- **Aircraft Recovery**

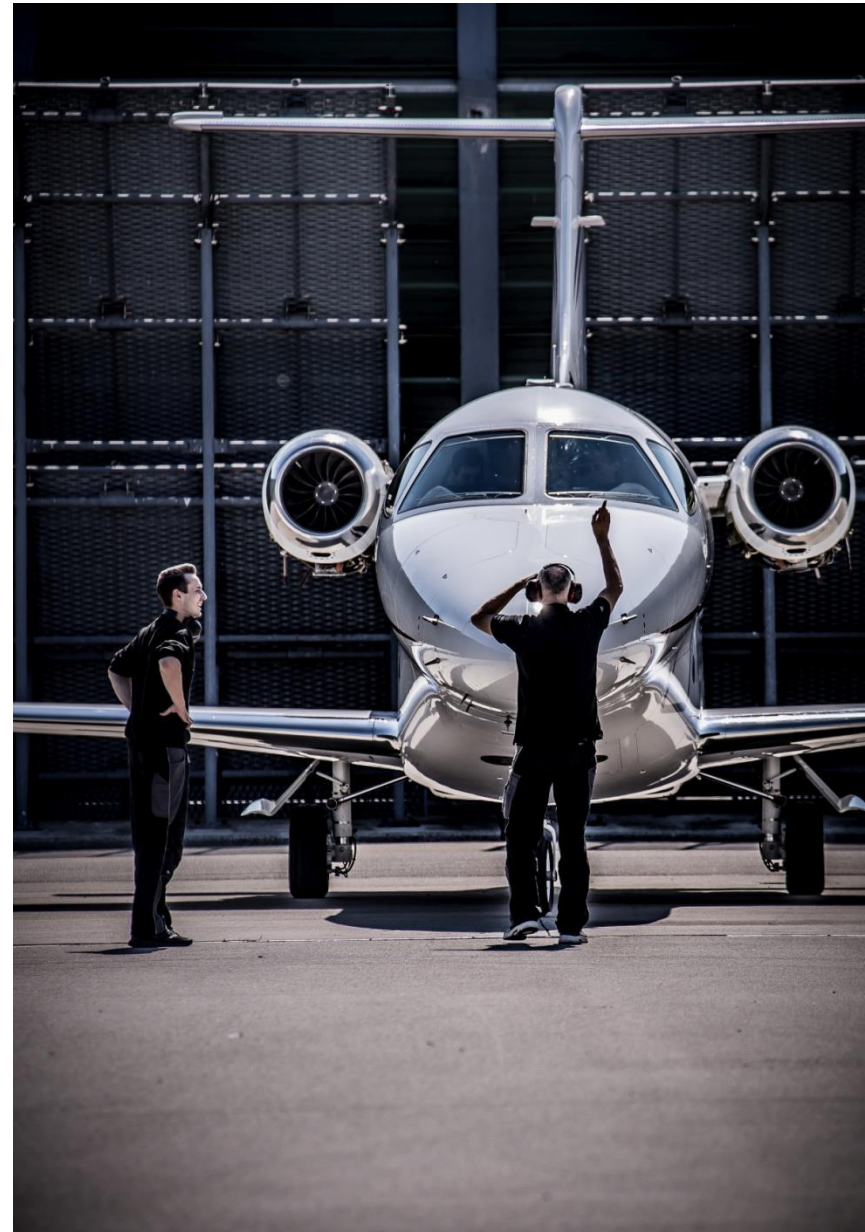

MRO Service



All Beechcraft Turboprops: King Air series 90, 200 and 350



**All Beechcraft Jets:
Premier I / Beechjet 400 / Hawker 400 XP / Nextant 400XT series**

MRO Service



Cessna Citation Jets: 510, 525, 525A/B and 560 XL



Embraer Executive Jets: Phenom 100 / 300



**Single and multi-engine pistons:
Beechcraft, Cirrus, Cessna, Piper & other (on request)**

- **Beechcraft King Air-Series**

**6-years inspection with
paint stripping available**

**Inspections, functional and
operational tests on**

- Beechcraft Premier I / IA
- Beechcraft Baron / Bonanza
- Cessna Citation 525 (A)
- Cessna Citation 560XL
- Cirrus SR20 / SR22
- Hawker 400XP / Beechjet 400A

- other aircraft (on request)



King Air 6-years inspection:
Step #9 reassembling of major parts

AOG Service



24 hours / 365 days per year – phone assistance + mobile team

- Installation, operational tests and repair of avionics of all leading brands
 - Conversion and refitting to state-of-the-art avionics (RVSM, TCAS, EGPWS, FDR, FMS, GPS, ADS-B)
 - Collins, Honeywell and Garmin systems as integrated solutions
 - Complete redesign of panels
-
- Service & repair for all instruments, e.g. navigation, flight / engine / airframe surveillance instruments
 - Mobile service für FAA examinations, e.g. XPDRs and altimeters



Paint Shop

- **Complete + partial painting**
- **Individual designs**
- **Registration changes
(affixed or coated)**
- **Extensive film work
(registration & company logos)**
- **Varnish repairs
(after hail or taxi damage etc.)**
- **Cleaning / Polishing / Sealing**
- **Special requests**

For various aircraft types
(metal + composite construction)



Interior

- **Major overhauls / refurbishments / rebuildings**
- **Complete interiors**
- **Special requests** (tables, bars etc.)
- **Seats & couches** (leather, cloth, fur)
- **Carpets / Curtains / Deck panels**
- **Custom made covers**
(for hand rail, propellers etc.)
- **Repair of individual parts**
(cushions / belts / carpet parts / wooden doors / tables)
- **Deep cleaning & conservation**

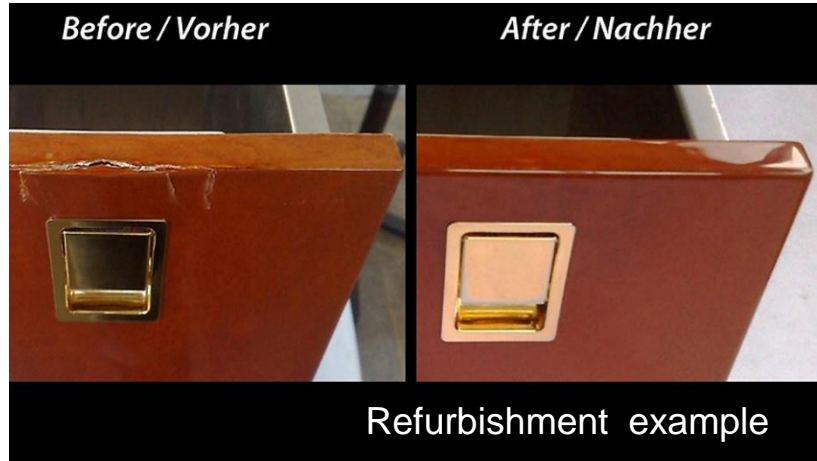

Our EASA Part-CAMO scope of work:

- Beechjet / Hawker 400 series
 - Beech King Air 300 series
 - Cessna Citation 560XL
 - Embraer Phenom 300
-
- Turbine aircraft up to 5700 kg
 - Piston aircraft up to 5700 kg
 - Single piston up to 2000 kg (metal + composite)



We take care of the entire airworthiness management for your business aircraft

Spare Parts Sales



- 11.000 items listed
- Mainly Beechcraft, Hawker, Cessna & Embraer spare parts
- Several spare parts for Cirrus, Piper, Mooney etc.

**Customs clearance (aircraft / goods) within our premises.
We procure non-stock items on short notice**



- **Modifications**
 - Airframe
 - Engine
 - Avionics
 - Special Mission Ambulance
- **Cirrus CAPS Overhaul**
- **Airline Trolley Maintenance**
- **and other (on request)**

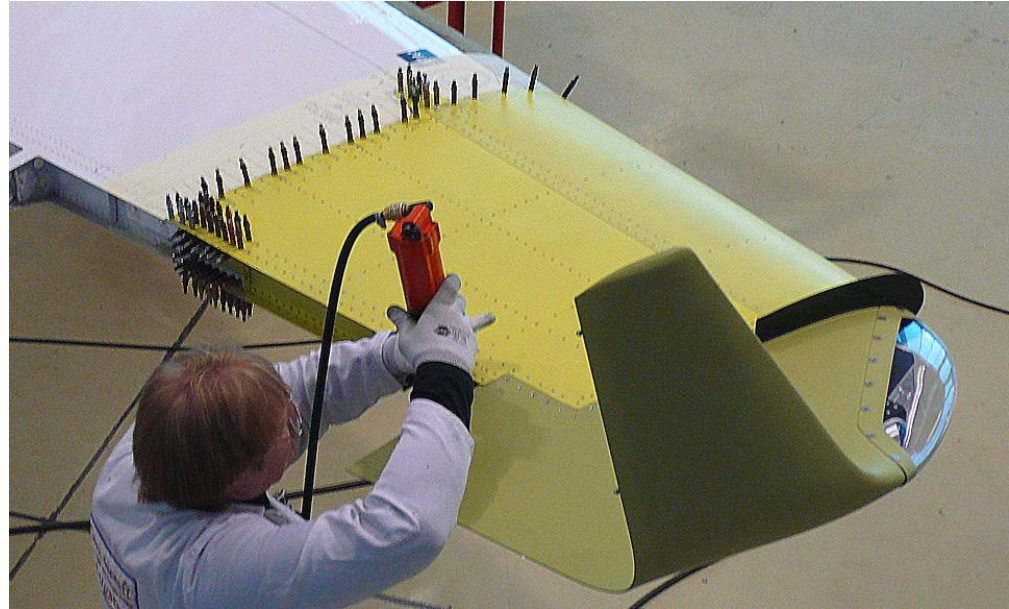

Mods & Upgrades



**We are specialized on Beechcraft King Air,
but also perform modifications on other aircraft types**

Mods & Upgrades (King Air)



Installation of single components and complete kits



- **Complete EPIC Kits**
- **Single Components:**
 - Turbofans / Swept Props
 - Dual Aft Body Strakes
 - RAM Air Recovery System
 - Enhanced Leading Edges
 - High Flotation Gear Doors
 - Wing Lockers



- Winglets
- Whisper Props
- Combined Kit



- Exhaust Stacks



- Cargo Pod
- Soft Touch Tires
- Exhaust Stacks



- BoomBeam Lights*
- LED Lights*

* also available for other aircraft

Exchange of standard- turbines by factory-new, more powerful PT6-A engines from Blackhawk

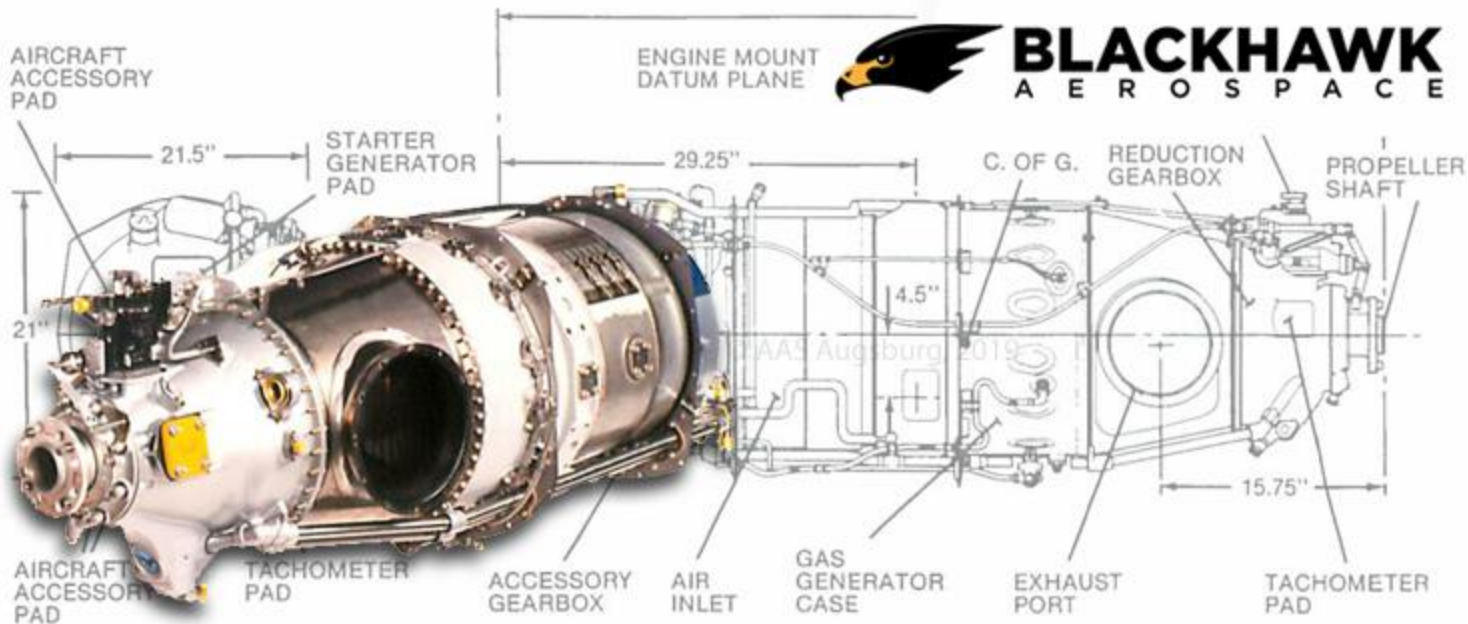

For King Air 90, 200 and 300 series

Mods & Upgrades: Avionics

Customized solutions for more safety

- **Conversion and refitting to state-of-the-art avionics** (RVSM, TCAS, EGPWS, FDR, FMS, GPS, P-RNAV, ADS-B Out)
- **Collins, Honeywell and Garmin avionics systems as integrated solutions**
- **Complete redesign of panels**



Special Mission Ambulance



Installation of medical packages as a customized solution

- Incubators
- Single or dual stretchers / sleds
- Modern patient loading systems, both electric and manual
- Attachments for securing medical monitoring devices
- Easy-to-clean vinyl sidewalls and floors



For King Air / Hawker / Cessna Citation / Embraer Phenom series

Cirrus Special (MRO & Mods)



- MRO services
- Cirrus CAPS Parachute OVH
- Reefing Line Cutter Replacement
- Installation of Cirrus Performance Brakes with tubeless tires

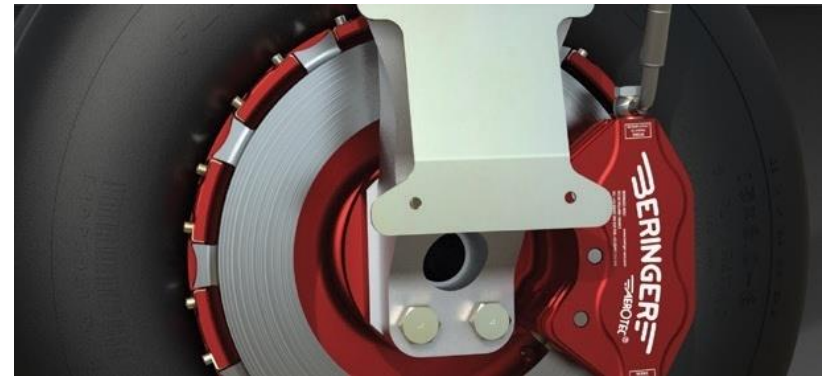

The only Authorized Service Center for Cirrus CAPS OVH in Germany

- **EASA Form 1 dual release (FAA)**
- **Airline trolley maintenance and repair**
- **Refurbishment**
- **Replacement of components (i.e brakes)**
- **Adjustment of mechanical parts**



In compliance with strict aviation regulations

Aircraft Sales



Pistons, Turboprops & Jets – Top aircraft of several brands

Our sales team will help you with:

- **Wide portfolio of traded and brokered aircraft**
- **World-wide network**
- **Acquisition / sales / ferry flights**
- **Pre-buy Inspections, registration and administrative support**
- **Financial advice**
- **Support in crewing**

Rely on our experience for best value!

Your Service Center for every Mission



... and how can we help you ?

More info:



www.aas-augsburg.de